



Project _____
Item # _____
Quantity _____
Submitted by _____



100-SERIES

The Saturn 100-Series gas convection ovens have over-sized cooking chambers that fit full-sized sheet pans side to side or front to back. These ovens provide the reliability and durability required by the rigorous demands of small to medium operators.

These ovens are available as single or double decks.

BAKERY-DEPTH GAS CONVECTION OVENS

Standard features include:

- Heavy-gauge stainless steel front, doors, door gaskets, and handles
- Aluminized sides and top
- Black powder coated leg assembly
- Fiber insulation at top, back, sides and bottom
- Porcelainized interior oven chamber for easy cleaning
- Two-speed 1/2 HP motor
- 80,000 BTU for exceptional cooking performance in high performance operations
- 50/50 doors for one-hand opening
- 60-minute timer with audible buzzer
- Solid state manual controls for timer, power and thermostat
- Manual heat shut-off switch
- Twelve rack positions with three racks



MODEL# 100-CO-1SD

(Shown with optional casters and bottom shelf with storage rack supports)
*Double deck oven not shown

100-SERIES BAKERY-DEPTH GAS CONVECTION OVENS





BAKERY-DEPTH GAS CONVECTION OVENS

100-SERIES

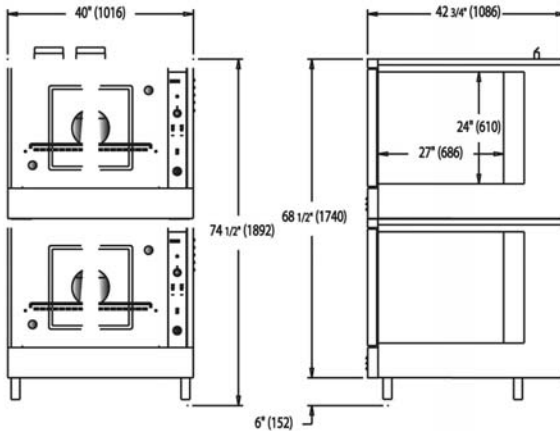
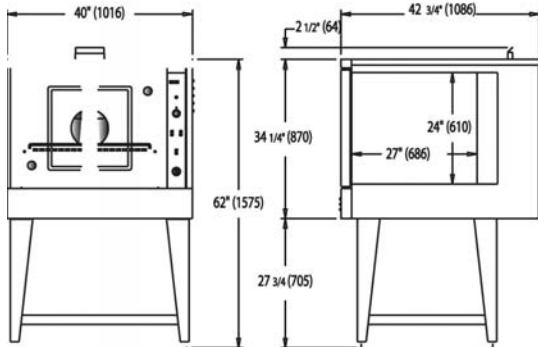
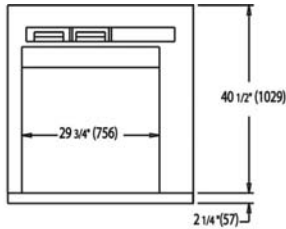
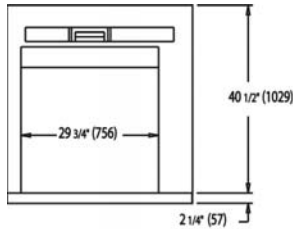

Model	Description	Width	Depth	Height	BTU	Weight
100-CO-1SD	Single deck, 2 solid stainless doors	40"	43"	64-1/2"	80,000	510
100-CO-2SD	Double deck, 2 solid stainless doors	40"	43"	74-1/2"	160,000	1,030

Gas:

- Manifold pressure is 5.0" W.C. for natural gas or 10.0" for LP gas
- Manifold size is 3/4" NPT
- Gas type and elevation (if to be operated at location over 2000 ft.) must be specified at time of order

Electric:

- 120 VAC, 1ph, 60 Hz, 9 Amps max (per oven)
- 2-speed, 1/2 HP motor at 1725 / 1140 RPM

Clearance:

For use only on non-combustible floors with legs or casters, or 2" overhang is required when curb mounted. 0" clearance from non-combustible side and rear walls. Provide 6" clearance from combustible sides and rear walls

Options:

- 4 casters (2 w/brake)
- Stacking kit
- Bottom shelf with storage rack supports
- Extra oven rack

Warranty:

One year parts and labor.



Saturn Cooking Equipment by Primoris Inc.

www.saturnequipment.com

We reserve the right to change materials and specifications without notice and without incurring any obligation for equipment previously sold.

Revised 0607