



MEDIUM DUTY GAS CHARBROILERS

ESCB-15 ESCB-24 ESCB-36 ESCB-48

FEATURES:

- Stainless and aluminized steel, fully welded construction to eliminate grease and dirt accumulation
- U-shaped burner design allows for efficient heat distribution and faster heat recovery
- Designed to be used with charbroiler rocks or radiant setup
- Cool touch bull-nose design protects user from hot surfaces
- Welded in place stainless steel side splash installed
- Heavy duty 6" legs with height adjustable bullet feet
- Full width drip pan tray for easy cleaning
- 19" cooking surface depth
- Shipped with natural gas - includes kit with regulator and field conversion for propane
- Narrow or wide burner grates dispense excess fat while reducing smoke and flames
- Rear adaptor bar for angled cooking grates allow for slower cooking and better heat control
- Cool touch chrome knobs with visible on/off indicators



ESCB-24

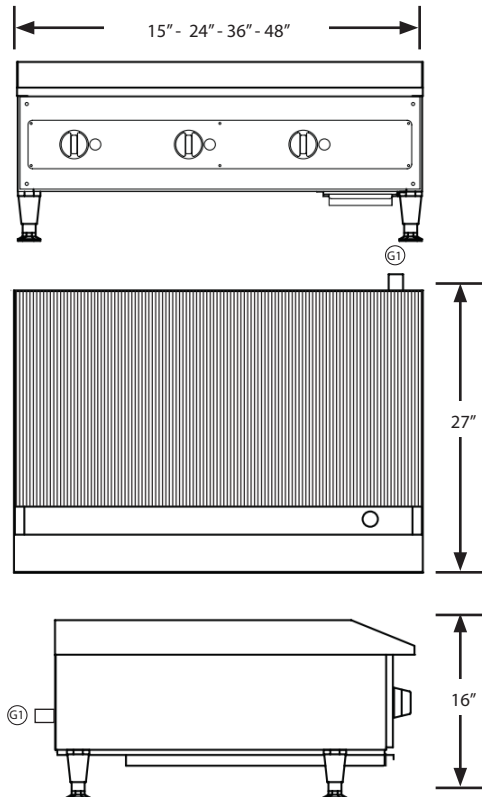

ESCB-15 MEDIUM DUTY 15" GAS CHARBROILER	
Dimensions (L X W X H)	27" x 15" x 16"
Power (Ⓢ)	3/4" NPT gas connection
BTU	28,000
Shipping weight	98 lbs
ESCB-24 MEDIUM DUTY 24" GAS CHARBROILER	
Dimensions (L X W X H)	27" x 24" x 16"
Power (Ⓢ)	3/4" NPT gas connection
BTU	56,000
Shipping weight	120 lbs
ESCB-36 MEDIUM DUTY 36" GAS CHARBROILER	
Dimensions (L X W X H)	27" x 36" x 16"
Power (Ⓢ)	3/4" NPT gas connection
BTU	84,000
Shipping weight	200 lbs
ESCB-48 MEDIUM DUTY 48" GAS CHARBROILER	
Dimensions (L X W X H)	27" x 48" x 16"
Power (Ⓢ)	3/4" NPT connection
BTU	112,000
Shipping weight	240 lbs

* In the pursuit of a better product, durability and performance. SATURN reserves the right to change specifications, materials and design without further notice.

Warranty: 1 year parts and labor.

Tel: 303-801-0680 Fax: 303-801-0681 info@saturnequipment.com www.saturnequipment.com