



SMDR-36-6

HEAVY DUTY STAINLESS STEEL COMMERCIAL GAS RANGE WITH FULL SIZE OVEN

FEATURES:

- Commercial duty gas range with stainless steel exterior
- Single 35,000 BTU oven with interior black enamel finish
- Stainless steel legs with 1" adjustable bullet feet.
- Insulated brushed stainless steel oven door handle
- Oven racking can be adjusted to 4 different heights
- Temperature controlled thermostat for precise control
- High rise stainless steel backsplash and shelf.
- Insulated oven door for added heat efficiency
- Oven temperature range 100° F -500° F degrees
- Heavy duty cast iron grates with built in burner protection
- Full width removable drip pan tray
- Cast iron grates are removable for day end cleaning
- Heat resistant cool to touch temperature control knobs
- Front access panel for easy maintenance
- Front plate is notched for lighting pilot lights
- 6 Heavy duty burners are 12" x 12" at 27,000 BTU each

SPECIFICATIONS: SMDR-36-6

Dimensions:	(L) 36" x (H) 58" x (W) 33"
Controls:	7
Oven:	1
Burners:	6
BTU:	197,000 Btu/hour
Weight:	398 lbs

* In the pursuit of a better product, durability and performance. SATURN reserves the right to change specifications, materials and design without further notice.

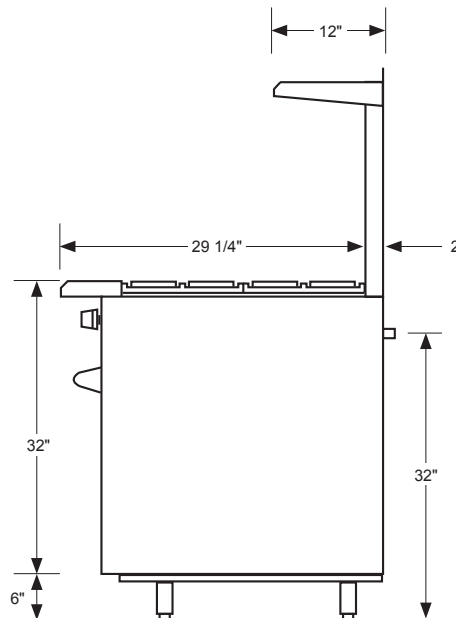
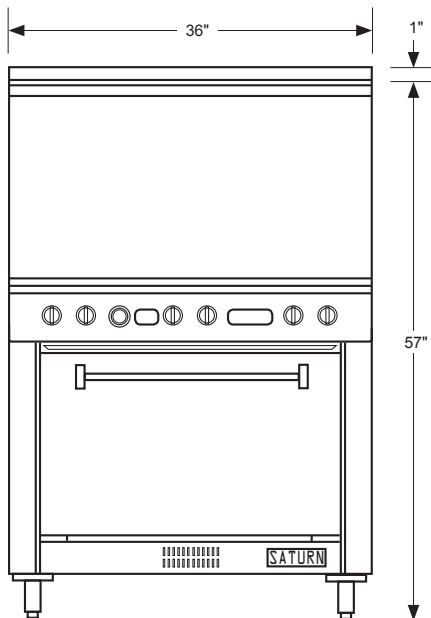

Warranty: 1 year parts and labor.

Tel: 303-801-0680 Fax: 303-801-0681 info@saturnequipment.com www.saturnequipment.com

ISaturn_Sixburner_SpecSheet 04/29/11

HEAVY DUTY GAS RANGE WITH OVEN

SMDR-36-6

www.saturnequipment.com