



## SUSS-27-8

### SINGLE DOOR STAINLESS STEEL SANDWICH PREP TABLE

27" SINGLE DOOR SANDWICH PREP REFRIGERATOR  
FEATURES:

- Durable stainless steel door
- Stainless steel interior and exterior
- Fully balanced self contained refrigeration system
- Easy grab recessed door handle
- High density CFC free polyurethane insulation
- Spring loaded self-closing door
- Installed 9 ft power cord comes standard
- Environmentally friendly R-134a refrigerant
- Components optimized for smooth quiet operation
- High density cutting board included
- Oversized compressor and coil section
- Heavy duty castors with two front brakes
- Height adjustable shelving for easy storage solutions

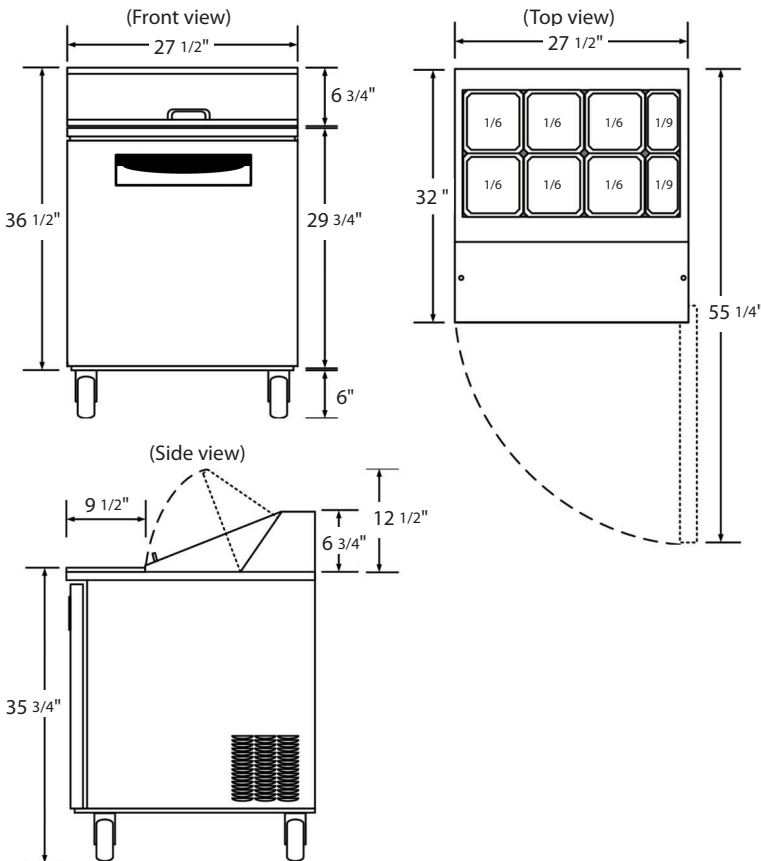

#### SPECIFICATIONS: SUSS-27-8

Doors	1 Stainless steel swing door
Capacity cu. ft.	7 Cu. Ft.
Shelves	1 Epoxy coated wire shelf
Compressor	1/5 HP
Pans Included	6pc @ 1/6th size - 2pc @ 1/9th size
Dimensions	27.5"W x 32"D x 42.5"H
Net Weight	198 lbs
Amps	3.2 A
Power	115V / 60Hz
Power Cord	9 Ft.
Temperature	32-40 Degrees F

\* In the pursuit of a better product, durability and performance. SATURN reserves the right to change specifications, materials and design without further notice.



Intertek

WARRANTY:  
1 year parts and labor.  
5 year compressor.