

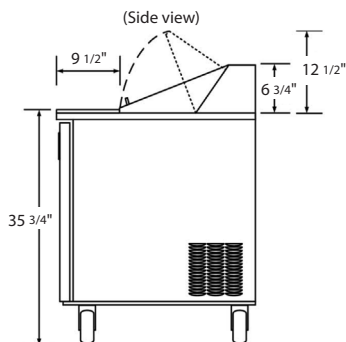

SUSS-72-18 TRIPLE DOOR STAINLESS STEEL SANDWICH PREP TABLE

72" TRIPLE DOOR SANDWICH PREP REFRIGERATOR
FEATURES:

- Durable stainless steel doors
- Stainless steel interior and exterior
- Fully balanced self contained refrigeration system
- Easy grab recessed door handles
- High density CFC free polyurethane insulation
- Spring loaded self-closing doors
- Installed 9 ft power cord comes standard
- Environmentally friendly R-134a refrigerant
- Components optimized for smooth quiet operation
- High density cutting board included
- Oversized compressor and coil section
- Heavy duty castors with two front brakes
- Height adjustable shelving for easy storage solutions

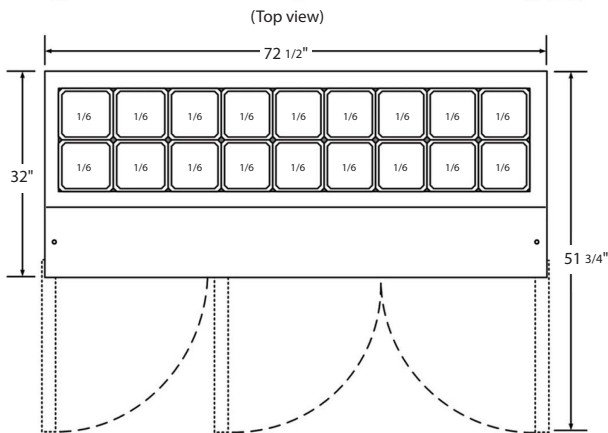
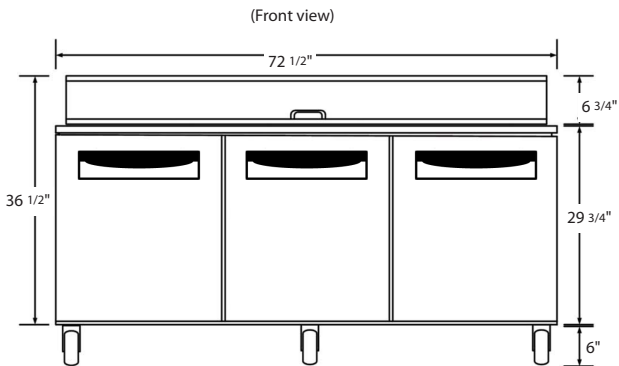

| SPECIFICATIONS: SUSS-72-18 | |
|----------------------------|-------------------------------|
| Doors | 3 Stainless steel swing doors |
| Capacity cu. ft. | 19 Cu. Ft |
| Shelves | 3 Epoxy coated wire shelves |
| Compressor | 3/8 HP |
| Pans Included | 18 pc @ 1/6th size container |
| Dimensions | 72.5"W x 32"D x 42.5"H |
| Net Weight | 348 lbs |
| Amps | 9.9 A |
| Power | 115V / 60Hz |
| Power Cord | 9 Ft |
| Temperature | 32-40 Degrees F |

* In the pursuit of a better product, durability and performance. SATURN reserves the right to change specifications, materials and design without further notice.

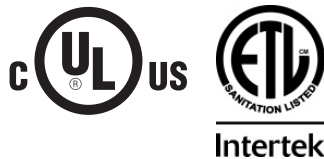

WARRANTY:
1 year parts and labor.
5 year compressor.