

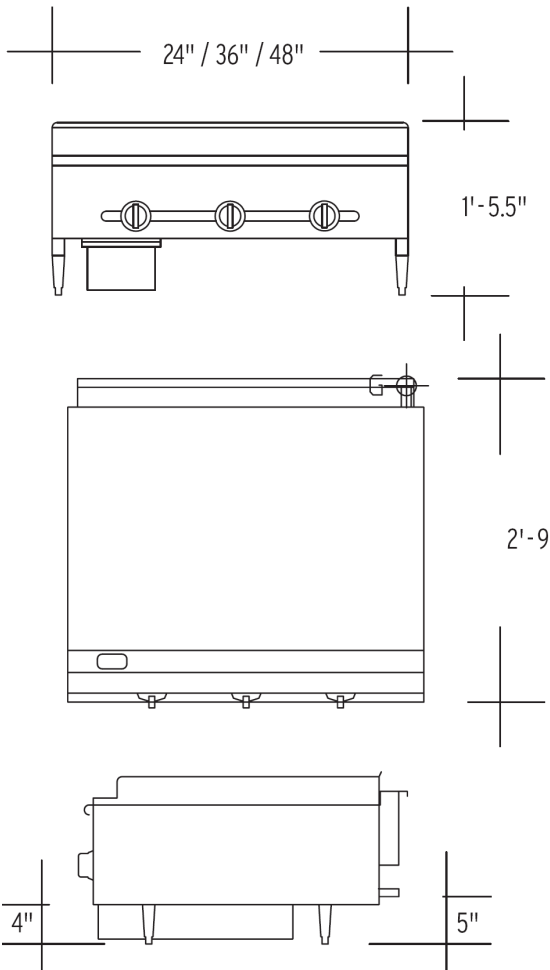

**TSG24-HD, TSG36-HD, TSG48-HD**  
**THERMOSTAT CONTROLLED**  
**GAS GRIDDLES - HEAVY DUTY**

**PRODUCT FEATURES:**

- Available in 24" , 36" or 48"
- Stainless steel construction
- Commercial grade 3/4" steel plate surface
- 1" Thick griddle plate available
- Convenient and easily removed drip drawer for effortless cleaning
- Individual control settings for each burner for heat control and versatility: Off/Low to High
- Even heat distribution
- 4" heavy duty chrome legs
- 4" Side splash and backsplash standard



SPECIFICATIONS: TSG24-HD	
Dimensions	24"W x 31.75"D x 17"H (incl. 4" legs)
Burners	2
Shipping Weight	250lbs / 113.5kg
Power	3/4" NPT connection
BTU	60,000 BTU/burner
L.P. Gas units also available	
SPECIFICATIONS: TSG36-HD	
Dimensions	36"W x 31.75"D x 17"H (incl. 4" legs)
Burners	3
Shipping Weight	396lbs / 180.5kg
Power	3/4" NPT connection
BTU	90,000 BTU/burner
L.P. Gas units also available	
SPECIFICATIONS: TSG48-HD	
Dimensions	48"W x 31.75"D x 17"H (incl. 4" legs)
Burners	4
Shipping Weight	508lbs / 230.5kg
Power	3/4" NPT connection
BTU	120,000 BTU/burner
L.P. Gas units also available	

\* In the pursuit of a better product, durability and performance. SATURN reserves the right to change specifications, materials and design without further notice.



**WARRANTY:**  
 1 year parts and labor.