



Project _____
 Item # _____
 Quantity _____
 Submitted by _____



500-SERIES

These heavy-duty, all-purpose fryers use a tube-fired heating design that rapidly heats the cooking oil to the set temperature. The high performance burners provide instant recovery for extreme product output.

HEAVY-DUTY GAS TUBE FRYERS

Standard features include:

- Heavy gauge stainless front, door, sides, flue riser and basket hanger
- Heavy 16-gauge, 304 stainless steel fry vessels
- Vessels are precision welded for strong, no-leak edges and seams
- Front sloping bottom traps food particles away from the fry zone to extend the life of the oil.
- Sturdy 6" high chrome-plated legs.
- Thermostatic control adjusts from 200°F to 400°F
- The millivolt control system eliminates the need for electrical hook-up
- Safety shut-off system completely shuts off the gas supply when the temperature reaches the factory-set hi-limit safety to prevent flare-ups
- 3/4" N.P.T. gas inlet is located in the rear of the fryer
- Countertop models use 20,000 BTU burners
- Floor production fryers use 38,000 BTU burners
- 1-1/4" drain valve
- Large removable mesh chrome-plated crumb screen under fry baskets



MODEL# 500-FRF-50
(Shown with optional casters)



MODEL# 500-FRC-25

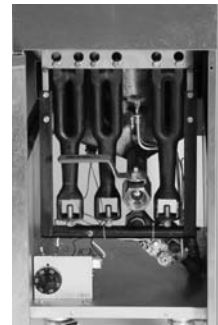

Inside detail



500-SERIES HEAVY-DUTY GAS TUBE FRYERS



HEAVY-DUTY GAS TUBE FRYERS

500-SERIES

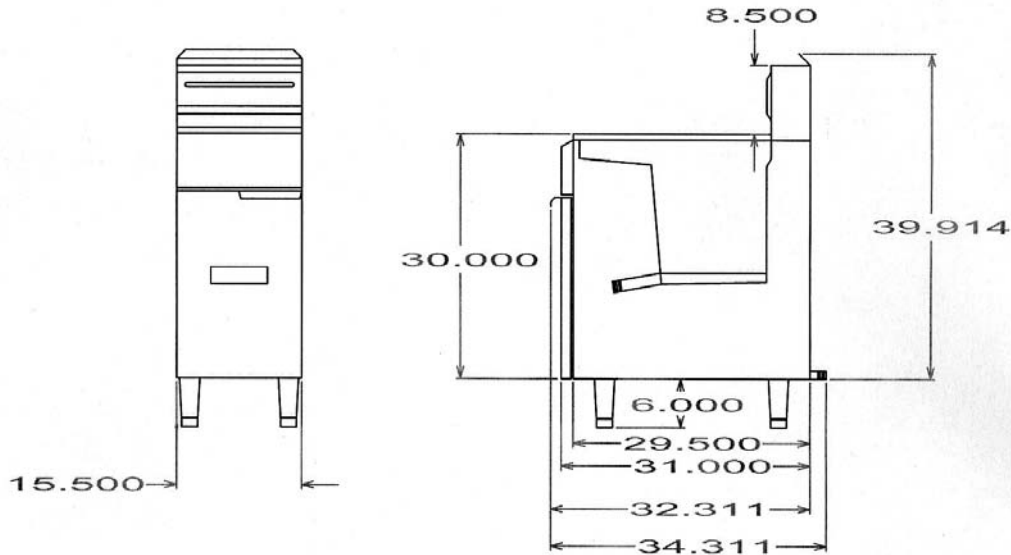

Model	Oil Capacity	Fry Area	Burners	Type	Width	Depth	Height	BTU	Weight
500-FRC-15	15 lb.	10" x 12"	2	Counter	12"	29-1/2"	20-3/4"	40,000	75
500-FRC-25	25 lb.	12" x 14"	3	Counter	15-1/2"	29-1/2"	20-3/4"	60,000	100
500-FRF-40	35-40 lb.	12" x 14"	2	Floor	15-1/2"	30-1/2"	45-3/4"	76,000	175
500-FRF-50	40-50 lb.	14" x 14"	3	Floor	15-1/2"	30-1/2"	45-3/4"	114,000	225
500-FRF-75	65-75 lb.	18" x 18"	4	Floor	19-1/2"	34-1/4"	45-3/4"	152,000	305

Gas:

- Mainfold pressure is 4.0" W.C. for Natural Gas or 11.0" for LP gas
- Mainfold size is 3/4" NPT
- Gas type and elevation (if to be operated at location over 2000 ft.) must be specified at time of order.

Clearance:

For use on non-combustible floors only. Legs or casters required for combustible floors. Provide 0" clearance from non-combustible surfaces. Provide 6" clearance from sides, rear and floor for combustible surfaces.

Options:

- 4 casters (2 w/brakes)
- Stainless vessel cover
- Extra fry baskets

Warranty:

One year parts and labor.



Saturn Cooking Equipment by Primoris Inc.

www.saturnequipment.com

We reserve the right to change materials and specifications without notice and without incurring any obligation for equipment previously sold.

Revised 0607